

MOTOMAN
a YASKAWA company

Motoman's revolutionary dual-arm DA20 robot provides "human-like" flexibility of movement to meet your automation needs

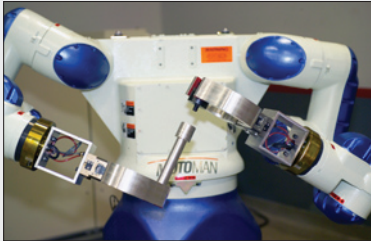

"JIGLESS" ASSEMBLY

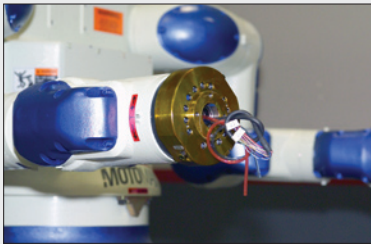

THRU-ARM CABLE AND HOSE ROUTING

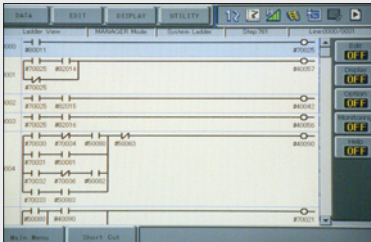

LADDER EDITOR

FEATURES & BENEFITS

- Single NX100 robot controller directs movement of all axes of the robot
- Handles 20 kg (44.1-lb) payload per arm; 40 kg (88.2 lbs) payload possible when using both arms
- Best-in-class wrist performance characteristics for your most demanding material handling tasks
- Repeatability: ± 0.1 mm (± 0.004 ")
- Reach: 765 mm (30.1") per arm from centerline of base rotation to tool mounting surface
- Opens up a wide range of applications to be performed by robots



ASSEMBLY • PACKAGING • HANDLING
MACHINE TENDING • PART TRANSFER

DA20

Payload: 20 kg/arm

High-Speed, Dual-Arm Robot with "Human-Like" Flexibility

The DA20 dual-arm robot provides high-speed motion with two six-axis arms that provide enhanced, "human-like" flexibility of movement, opening up a wide range of applications to be performed by robots. This revolutionary, innovative design makes the DA20 robot ideally suited for a wide variety of assembly, packaging, part transfer, machine tending and other handling tasks that formerly could only be done by people. The unique DA20 features 13 axes of motion (six axes per arm, plus a single axis for base rotation).

The DA20 robot has a 20 kg (44.1 lb) payload per arm, a 765 mm (30.1") reach per arm (from centerline of base rotation to tool mounting surface), and a repeatability of ± 0.1 mm (0.004"). Both robot arms can work together to double the payload or accomplish intricate tasks. In addition, both robot arms can perform tasks independently without degradation of throughput. The DA20 robot can also transfer a part from one of its arms to the other with no need to re-grip the part. It also provides "jigless" operation,

allowing one robot arm to hold the part while the other performs the required process(es).

Advanced NX100 Controller

The DA20 robot is controlled by the Motoman NX100 robot controller that features a robust PC architecture, Windows® CE programming pendant, and easy-to-use INFORM III programming language.

The NX100 offers unmatched multiple axes control capability to maximize flexibility while minimizing cost of integration and eliminating risk of robot collisions. Dual-channel safety features include enhanced E-stop functionality, integrated speed monitoring, manual brake release switches, and compliance with both ANSI/RIA R1506-1999 and Canadian safety standards.

The NX100 controller offers unmatched connectivity through standard Ethernet and other network options, including: DeviceNet, ControlNet, Profibus-DP, and EtherNet/IP. The programming pendant features a color touch-screen display that can be configured as a custom HMI (Human Machine Interface) with buttons and status indicators.

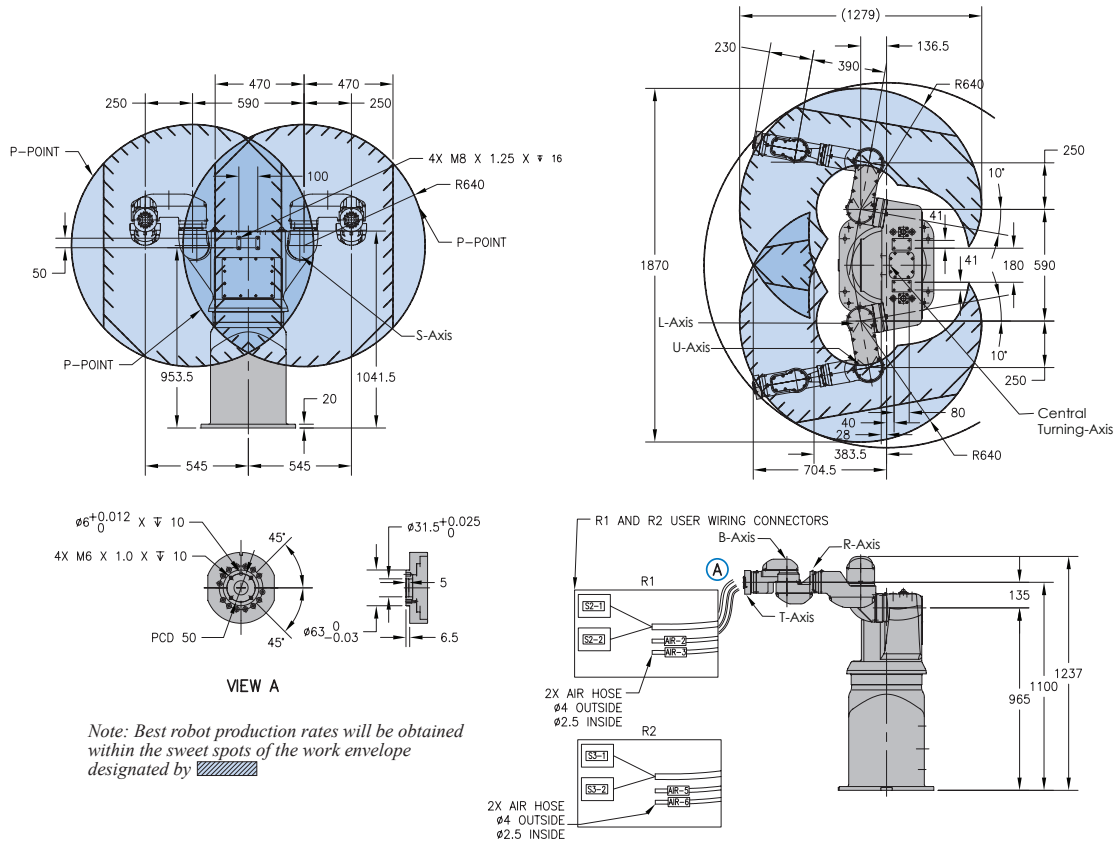

DA20 SPECIFICATIONS

Structure	Articulated	
Mounting	Floor	
Controlled Axes	13 (6 axes per arm and 1 rotary axis)	
Payload	20 kg (44.1 lbs)/arm	
Horizontal Reach per Arm	765 mm (30.1")	
Vertical Reach	640 mm (25.2")	
Repeatability	±0.1 mm (±0.004")	
Maximum Motion Range	Central Turning Axis S-Axis (Turning)	±180° R1: +80°/-190° R2: +190°/-80°
	L-Axis (Lower Arm)	+230°/-30°
	U-Axis (Upper Arm)	+215°/-35°
	R-Axis (Upper Arm Twist)	±180°
	B-Axis (Wrist Pitch/Yaw)	±120°
	T-Axis (Wrist Twist)	±180°
Maximum Speed	Turning-Axis	170°/s
	S-Axis	170°/s
	L-Axis	170°/s
	U-Axis	170°/s
	R-Axis	300°/s
	B-Axis	300°/s
	T-Axis	580°/s
Approximate Mass	240 kg (529.2 lbs)	
Power Consumption	4.2 kVA	
Allowable Moment	R-Axis	58.8 N · m
	B-Axis	58.8 N · m
	T-Axis	29.4 N · m
Allowable Moment of Inertia	R-Axis	4 kg · m ²
	B-Axis	4 kg · m ²
	T-Axis	2 kg · m ²

NX100 CONTROLLER SPECIFICATIONS*

Structure	Free-standing, enclosed type
Dimensions (mm)	1,300 (w) x 1,200 (h) x 650 (d) (51.2" x 47.2" x 25.6")**
Approximate Mass	150-250 kg (330.8-551.3 lbs.)
Cooling System	Indirect cooling
Ambient Temperature	During operation: 0° C (32° F) to 45° C (113° F) During transmit and storage: -10° C (14° F) to +60° C (140° F)
Relative Humidity	90% max. non-condensing
Primary Power Requirements	3-phase, 240/480/575 VAC at 50/60 Hz
Grounding	Grounding resistance: ≤100 ohms Separate ground required
Digital I/O	Standard I/O: 40 inputs/40 outputs consisting of 16 system inputs/16 system outputs, 24 user inputs/24 user outputs Enabled to 1,024 inputs/1,024 outputs
Position Feedback	By absolute encoder
Drive Units	Servo packs for AC servo motors
Accel/Decel	Software servo control
Program Memory	60,000 steps, 10,000 ladder instructions
Pendant Dim. (mm)	199 (w) x 338 (h) x 60 (d) (7.8" x 13.3" x 2.4")
Pendant Playback Buttons	Teach, Play, Remote, Servo On, Start, Hold, Emergency Stop, Edit Lock (Play Mode Enabled on Controller)
Concurrent I/O Ladder	10,000 Instructions
Multi Tasking	Up to 8 concurrent jobs
Fieldbus	DeviceNet Master/Slave, AB RIO, Profibus, Interbus-S, M-Net, CC Link, EtherNet IP/Slave
Ethernet	10 Base T/100 Base TX
E-Stop	Controlled stop
Safety	Dual-channel Emergency Stop Pushbuttons, 3-position Enable Switch, Manual Brake Release Meets ANSI/RIA R15.06-1999 and Canadian safety standards

*See NX100 Controller data sheet (DS-232) for complete specifications

**Please allow additional space for the robot controller due to cable connections and other installation requirements