

ARC Mate® 50iC/5L

FANUC
Robotics

Basic Description

The new ARC Mate 50iC/5L is the latest arc welding offering from FANUC Robotics. The slim arm profile improves part and tooling accessibility while the lighter weight enables fast speeds. The profile also makes it the ideal solution for welding applications where space is a premium and throughput is a must.

Payload is a class-leading 5 kg, allowing for easy interchangeability with existing welding torches used in much larger class robots minimizing inventory overhead. The robot controller and easy-to-use ArcTool® software provide reliable performance with higher productivity.



Benefits

- Best-in-class reach versus stroke with 892 mm reach and 616 mm stroke.
- Best-in-class speed.
- Best-in-class payload and weight with highest wrist moment and inertias.
- +/- 0.03 mm repeatability.
- Higher rigidity and the most advanced servo technology enable smooth motion without vibration in high-speed operation.
- Tabletop size, slim wrists, and small footprint permit operation in tight work spaces.
- Robot can flip over backwards for a larger work envelope.
- Enclosed mechanical design eliminates cables and hose snagging.

- Extremely compact controller cabinet.
- Upright, angle, wall or invert mounting increases installation flexibility.
- Same footprint and wrist bolt pattern as previous generation for easy upgrades.
- *iPendant™*, a color, Internet-ready teach pendant for even easier programming and custom cell user interface design.

Robot Reliability

- The latest generation of a proven design.
- Sealed bearings and brushless AC motors.
- Standard “C” size batteries for encoder backup.
- Fail-safe mechanical brakes on all joints.
- Standard IP67 rating for the entire robot allows it to withstand harsh environments

Robot and Controller Options

- 110 VAC single-phase input voltage.
- 360-degree J1 axis rotation.
- Extended communication capabilities: Ethernet, FTP, Serial and DeviceNet.
- Supports ArcLink® & ArcLink® XT.
- Supports a variety of intelligent functions including an internal programmable machine controller (PMC) and *iRVision®* (built-in vision-ready controller).

Note: ARC Mate® and *iRVision®* are registered trademarks of FANUC LTD.

ARCLink® is a registered trademark of Lincoln Electric.

R-30iA Mate Controller

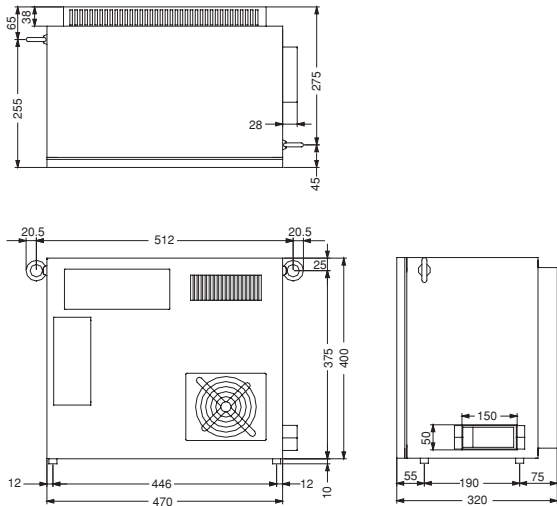

Footprint

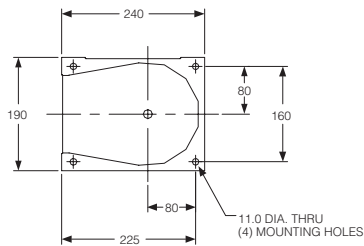

ARC Mate 50iC/5L Dimensions

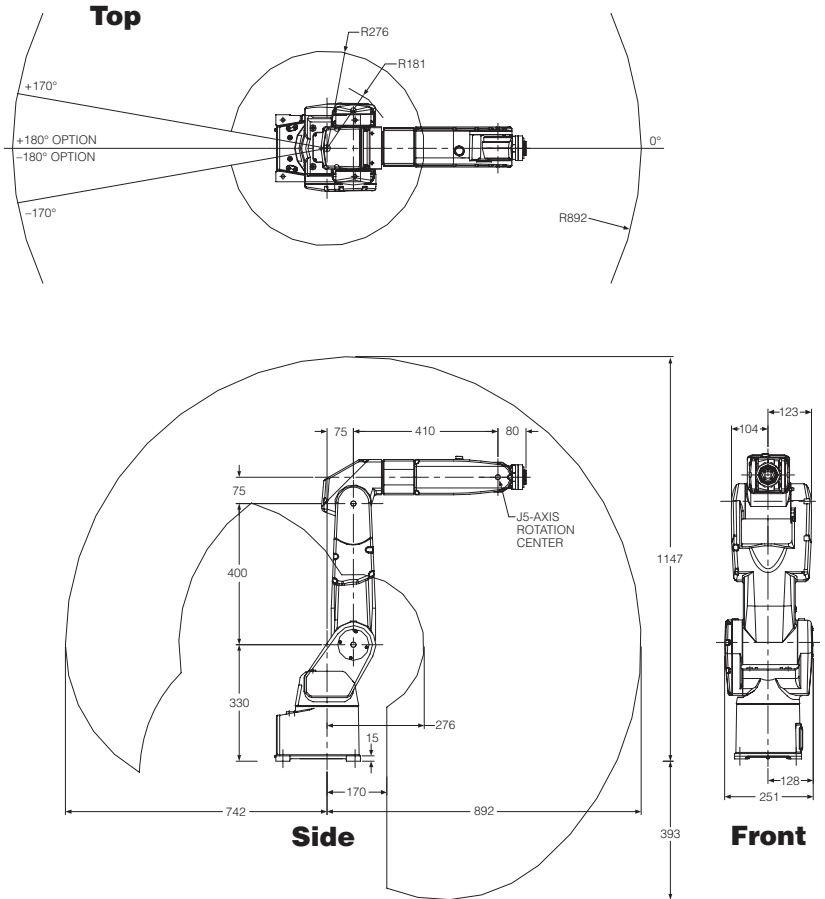

ARC Mate 50iC/5L Specifications

Items		
Axes	6	
Payload (kg)	5	
Reach (mm)	892	
Repeatability (mm)	±0.03	
Motion range (degrees)	J1	340 (360 option)
	J2	230
	J3	373
	J4	380
	J5	240
	J6	720
Motion speed (degrees/s)	J1	270
	J2	270
	J3	270
	J4	450
	J5	450
	J6	720
Wrist moments N-m (kgf-m)	J4	11.9 (1.21)
	J5	11.9 (1.21)
	J6	6.7 (0.68)
Wrist load inertia (kg-m ²)	J4	0.3
	J5	0.3
	J6	0.1
Mechanical brakes	All axes	
Mechanical weight (kg)	29	
Mounting method ⁽¹⁾	Floor, ceiling, angle, and wall	
Installation environment		
Temperature (°C)	0 to 45	
Humidity	Normally: 75% or less Short term (within a month): 95% or less No condensation	
Vibration (m/s ²)	0.5 or less	

Notes:
(1) J1 and J2 axis motion range will be limited for angle and wall mount installations.

Wrist

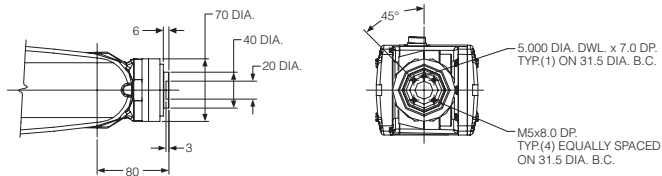

Intelligent Robot Solutions

FANUC
Robotics

FANUC Robotics America, Inc.
3900 W. Hamlin Road
Rochester Hills, MI 48309-3253

Charlotte, NC
(704) 596-5121

Toronto, Canada
(905) 812-2300

Chicago, IL
(847) 898-6000

Montréal, Canada
(450) 492-9001

For sales or technical information, call:
1-800-iQ-ROBOT

Cincinnati, OH
(513) 754-2400

Aguaascalientes, Mexico
52 (449) 922-8000

Los Angeles, CA
(949) 595-2700

Sao Paulo, Brazil
(55) (11) 3619-0599

marketing@fanucrobotics.com
fanucrobotics.com

Toledo, OH
(419) 866-0788

©2008 FANUC Robotics America, Inc. All rights reserved. FANUC ROBOTICS LITHO IN U.S.A. FRA-9/08