

# LR Mate® 200iC Series & R-30iA™ Mate Controller

## Basic Description

The new LR Mate 200iC Series is FANUC Robotics' next generation, electric servo-driven mini-robot series offering best-in-class performance in a light, efficient, accurate and nimble (LEAN) package. The new LR Mate 200iC's tabletop size, slimmer arm profile, lighter weight, highest dexterity, faster sustained speed and superior positioning accuracies make it the perfect solution for countless industrial and commercial applications.

## LR Mate 200iC, the Solution for:

- Machine tending
- Material handling
- Assembly
- Picking and packing
- Part washing
- Material removal
- Dispensing
- Testing and sampling
- Education and entertainment

## Features and Benefits

- 5 or 6 degrees of freedom
- ±0.02 mm (200iC & 200iC/5H) and ±0.03 mm (200iC/5L) repeatability at full payload and full speed within entire robot work envelope
- Up to 5 kg payload at wrist
- Best-in-class wrist moment and inertias for real-world EOATs and workpieces
- Pneumatic and electrical (6 RDI) connections for EOAT conveniently located on J4
- Two, double-acting solenoid valves integrated in forearm simplify EOAT dressout (no built-in valves on 200iC/5H SCARA Eliminator model)
- Highest joint speeds maximize throughput
- Tabletop size, slim wrist, and small footprint permit operation in tight work spaces.
- Robot can flip over backwards for a larger work envelope
- Enclosed mechanical design eliminates cables and hose snagging
- Upright, angle, wall or invert mounting increases installation flexibility



- Higher rigidity and the most advanced servo technology enable smooth motion without vibration in high speed operation
- Advanced communication capabilities via standard Ethernet and serial connections
- Integrated PMC provides ladder-logic control for peripheral devices
- Lighter and more compact than its predecessor
- The arm profile cross-section area is 42% smaller than the previous generation LR Mate 200iB
- Same footprint and wrist bolt pattern as previous generation for easy upgrades

## Robot Reliability

- The latest generation of a proven design
- Sealed bearings and brushless AC motors
- Standard "C" size batteries for encoder backup
- Grease fittings on all lubrication points for quick and easy preventive maintenance

## Robot and Controller Options

- 110 VAC single phase input voltage
- 360-degree J1 axis rotation
- Fail-safe mechanical brakes on all joints

- Available R-30iA Mate rack mount compact controller fits in standard 19" electronics rack and is ideal for climate controlled applications such as food, lab, pharmaceutical, medical and education.
- *iPendant™*, a color, Internet-ready teach pendant for even easier programming and custom cell user interface design
- Extended networked I/O capabilities: I/O Link, DeviceNet, Profibus
- Supports a variety of intelligent functions including *iRVision®* (built-in vision-ready controller) and force sensing
- Available IP67 rating for the entire robot allows it to withstand harsh environments
- 7 m or 14 m controller-to-robot connection cables

## Unique Software Options

- Patented real-time singularity avoidance
- Collision protection
- Internet connectivity
- KAREL® programming language
- Many more software solutions for control, communication, and motion

Note: LR Mate® and *iRVision®* are registered trademarks of FANUC LTD.

**FANUC**  
Robotics

## Dimensions

### LR Mate 200iC, 5H, 5WP, /5C

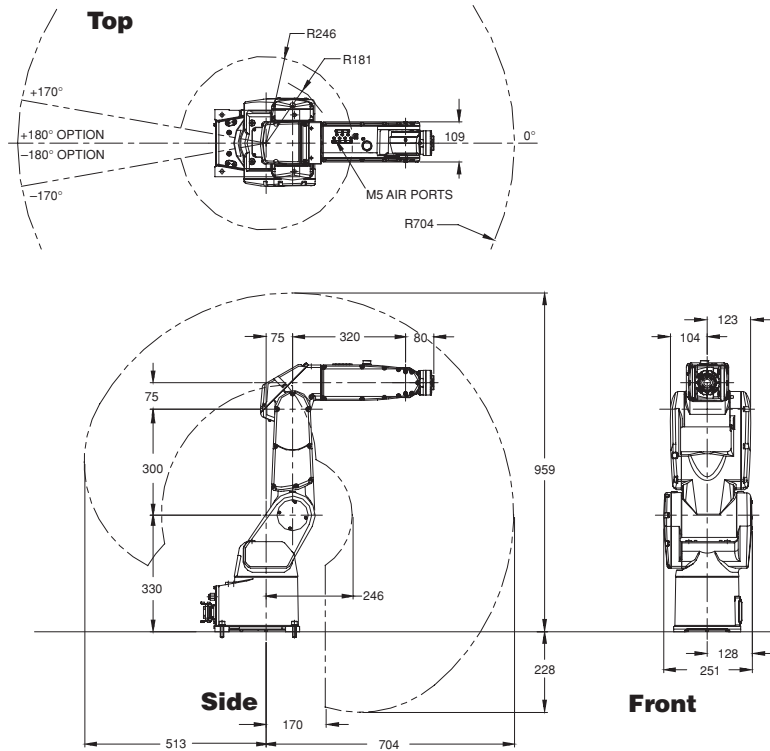

### LR Mate 200iC/5L, /5LC

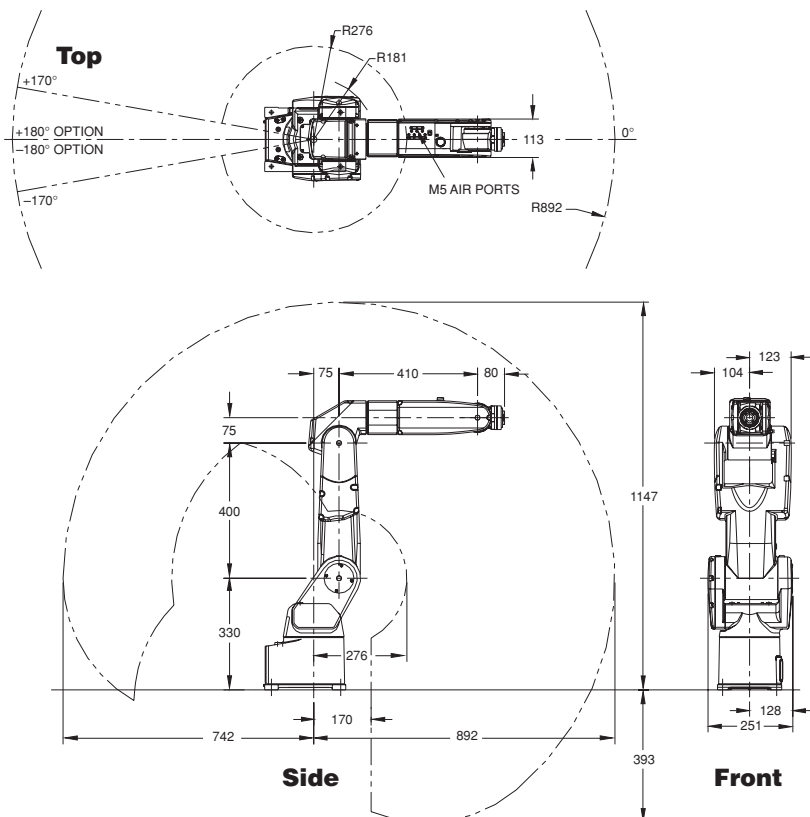

## LR Mate 200iC Isometric



### Footprint (All models)

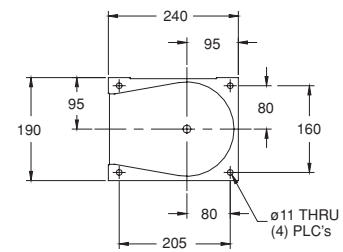

### Wrist (All models)

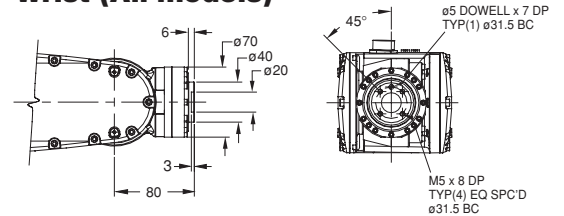

## LR Mate 200iC/5L Isometric



**Note:** Dimensions are shown in millimeters.  
Detailed CAD data are available upon request.

## LR Mate 200iC Series Robot Specifications

Items	LR Mate 200iC			
	LR Mate 200iC/5WP LR Mate 200iC/5C	LR Mate 200iC/5H	LR Mate 200iC/5L LR Mate 200iC/5LC	
Axes	6	5	6	
Payload - wrist (kg)	5	5	5	
Reach (mm)	704	704	892	
Repeatability (mm)	±0.02	±0.02	±0.03	
Interference Radius (mm)	181	181	181	
Motion range (degrees)	J1	340 (360 option)	340 (360 option)	340 (360 option)
	J2	200	200	230
	J3	388	388	373
	J4	380	240	380
	J5	240	720	240
	J6	720	-	720
Motion speed (degrees/s)	J1	350	350	270
	J2	350	350	270
	J3	400	400	270
	J4	450	450	450
	J5	450	720	450
	J6	720	-	720
Wrist moments N-m (kgf-m)	J4	11.9 (1.21)	11.9 (1.21)	11.9 (1.21)
	J5	11.9 (1.21)	6.7 (0.68)	11.9 (1.21)
	J6	6.7 (0.68)	-	6.7 (0.68)
Wrist load inertia (kg-m <sup>2</sup> )	J4	0.3	0.3	0.3
	J5	0.3	0.1	0.3
	J6	0.1	-	0.1
Mechanical brakes	All axes	J1, J2 & J3 (all axes option)	All axes	
Mechanical weight (kg)	27	26	29	
Mounting method <sup>(1)</sup>	Floor, ceiling, angle and wall			
Installation environment				
Temperature (°C)	0 to 45			
Humidity	Normally: 75% or less Short term (within a month): 95% or less No condensation			
Vibration m/s <sup>2</sup> (G)	0.5 or less			
IP Rating(s)	IP 67 entire robot (option)	IP 67 entire robot (option)	IP 67 entire robot (option)	

Note: (1) J1 and J2 axes motion range will be limited for angle and wall mount installations.

## R-30iA Mate Controller Specifications

Items	
External Dimensions (mm)	- 470(W) x 320(D) x 400(H) for RIA - Option: 590(W) x 320(D) x 400(H) for CE - Option: 370(W) x 455(D) x 200(H) for rack mount compact
Operating Environment	- Ambient temperature: 0 - 45 °C (R-30iA Mate) - Ambient temperature: 0 - 30 °C (R-30iA Mate rack mount) Humidity: 75% RH or less; Short term (within a month): 95% or less Vibration: 0.5G or less
Power Supply	- 200-230VAC Single Phase; 10%, -15%, 50/60 Hz ± 1Hz - Option: 120VAC Single Phase (requires top or side cabinet)
Power Consumption	- 0.5 KW (average), 1.2 KVA (maximum)
CPU	- Multi-processor architecture (separate motion and communication) with real-time clock/calendar
Controlled Axes	- 24 (up to 5 motion groups for R-30iA Mate)
Serial/host communications	- One 100 Base-TX/10 Base-T Ethernet port with RJ-45 connector - One RS-232-C / RS-485 port
Teach Pendant	- Color graphic iPendant™ with available touch screen option (teach pendant is optional for LR Mate 200iC/5H SCARA Eliminator)
iRVision™	- Built-in camera interface for 2-D vision applications Optional: multiplexer for multiple 2-D cameras and 3-D vision
Built-in I/O	- Up to 28 digital inputs / 24 digital outputs 24VDC (external 24VDC power supply is required for digital outputs)
Safety Features	- Dual Check Safety (DCS) circuit
Memory Card	- PCMCIA type 2 interface: ATA flash disk (SanDisk compatible)
Mass (kg)	- 55 (R-30iA Mate RIA)
<b>R-30iA Mate Controller Options:</b>	
I/O sub-systems	- Model A I/O (remote mounted modular rack- 5 or 10 slots) - Model B I/O (distributed DIN rail mounted) - FANUC I/O link
Remote I/O sub-systems	- DeviceNet (slave up to single channel) - Profibus DP slave/master - CC-Link (slave) - Ethernet I/O (EGD and EIP Adapter/Scanner)
Integrated PMC	- Ladder logic control for peripheral devices - Including ladder monitor with hot edit on iPendant
iRVision™	- Remote mounted multiplexer to support up to four 2-D cameras and/or four 3-D laser units
Force Sensing	- FS-10iA force sensor interface option Rated load capacity: 10 kgf
Intelligent Parts Feeder	- Flexible turn-key feeder package driven off R-30iA Mate controller - Includes auxiliary axis & iRVision/2D vision package
Servo-Driven RTU Package	- Standard 0.5m and 1m linear ball-screw driven RTU with Aux. Axis

## R-30iA Mate Controller Dimensions

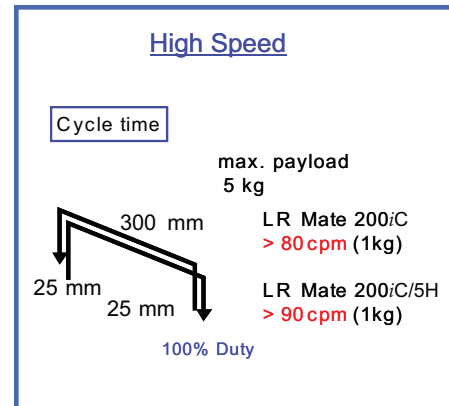
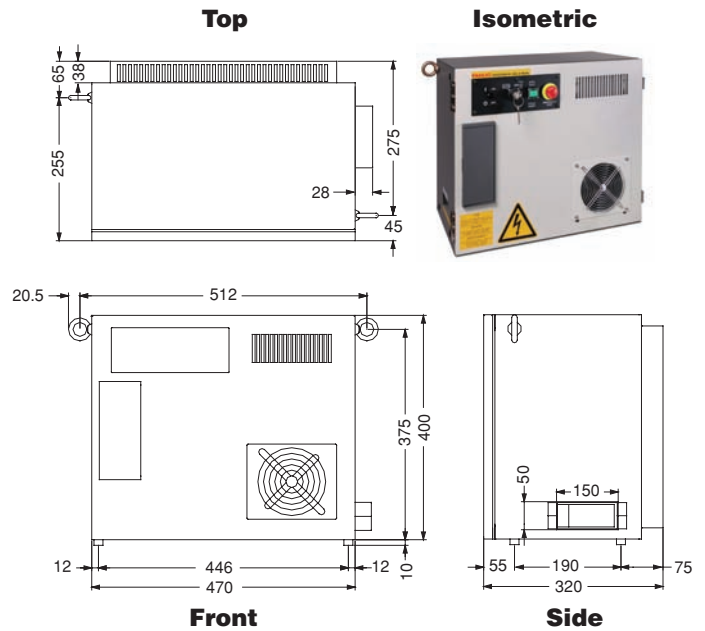

## R-30iA Mate (rack mount) Controller Dimensions

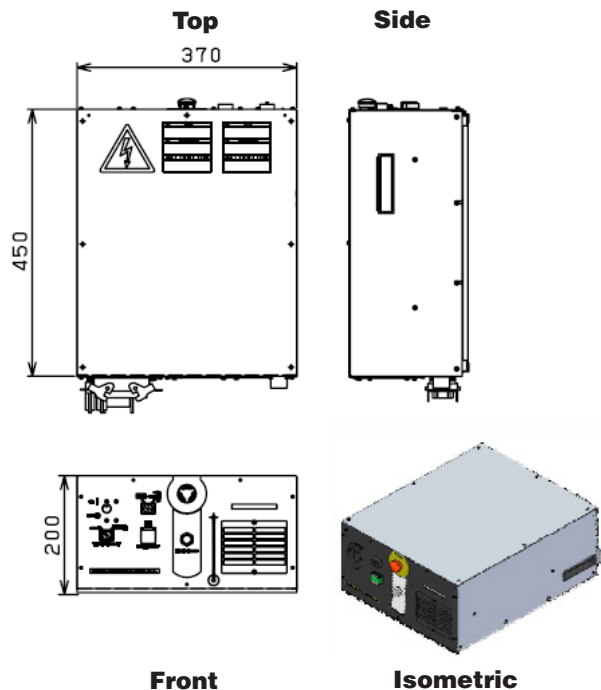

## LR Mate 200iC Series Application Examples



LR Mate 200iC – Ideal for variety of material handling and machine tending applications!!



Cleanroom LR Mate 200iC/5C - the right choice for semiconductors & pharmaceutical applications!

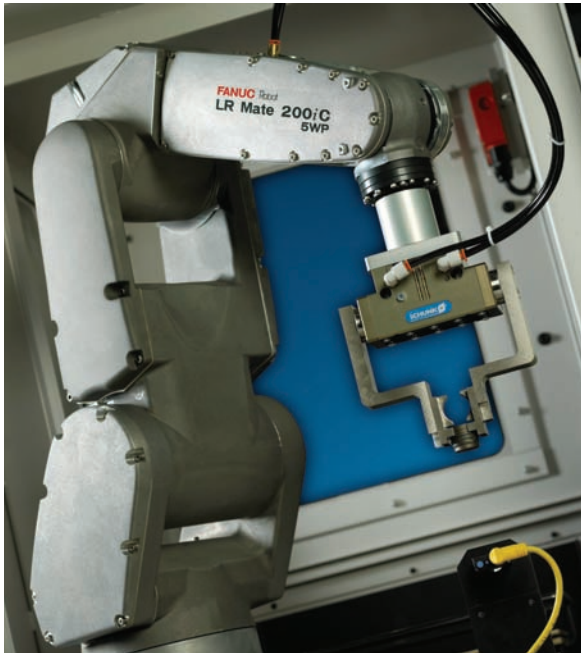

Tough and rugged LR Mate 200iC/5WP used for high pressure washing, deburring and cleaning applications!



LR Mate 200iC picks & sorts multiple style parts through flexible feeder using built-in iRVision and available Aux. Axis option!

### Intelligent Robot Solutions

**FANUC**  
Robotics

**FANUC Robotics America, Inc.**  
3900 W. Hamlin Road  
Rochester Hills, MI 48309-3253

Charlotte, NC  
(704) 596-5121

Toronto, Canada  
(905) 812-2300

Chicago, IL  
(847) 898-6000

Montréal, Canada  
(450) 492-9001

**For sales or technical information, call:**  
**1-800-iQ-ROBOT**

Cincinnati, OH  
(513) 754-2400

Aguascalientes, Mexico  
52 (449) 922-8000

Los Angeles, CA  
(949) 595-2700

Sao Paulo, Brazil  
(55) (11) 3619-0599

**marketing@fanucrobotics.com**  
**fanucrobotics.com**

Toledo, OH  
(419) 866-0788

©2008 FANUC Robotics America, Inc. All rights reserved. FANUC ROBOTICS LITHO IN U.S.A. FRA-9/08